

REFRIGERATOR FEATURES AND SPECIFICATIONS

RETROPOLITAN

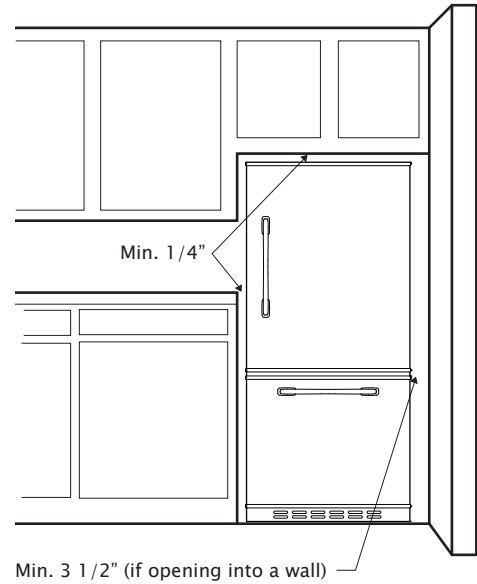
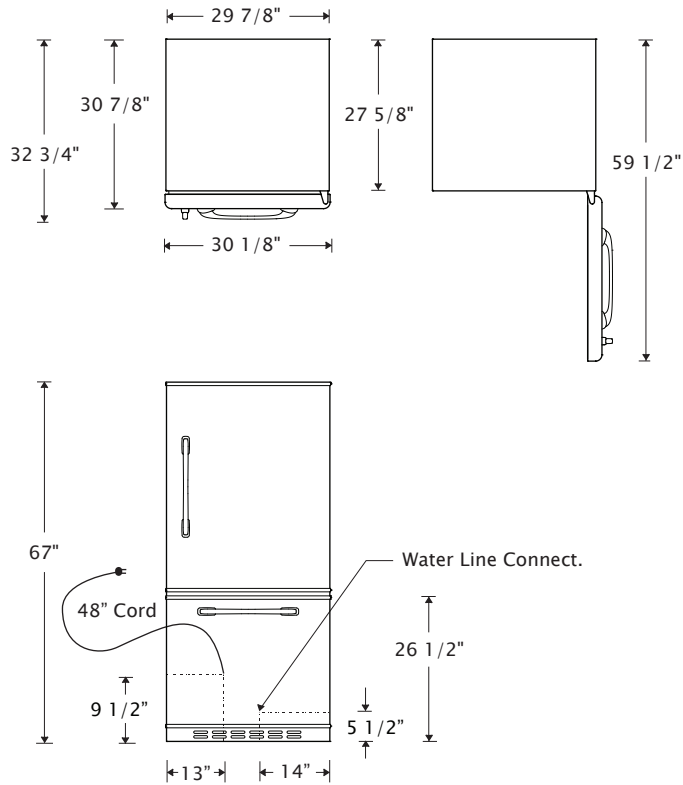

| | |
|------------------------------------|---|
| Total Capacity | 18.7 cu. ft. |
| Refrigerator Capacity | 13 cu. ft. |
| Freezer Capacity | 5.7 cu. ft. |
| Clearance: Back | 1/2" |
| Clearance: Side | 1/4" |
| Side Clearance for door to open 90 | 3 1/2" |
| Adjustable Rollers | Standard |
| Energy Guide (kWh/year) | 553 |
| Electrical | 115V, 60Hz, AC only, 15 or 20 amp fused |
| Shipping Weight | 400 lbs |

FEATURES:

Stamped Metal Body, Chrome Trim, Gallon Door Storage, 2 Half-Width Clear Crisper Drawers, Four Half-Width Adjustable Glass Shelves, Slide-Out Upper Freezer Basket, Glide-Out Freezer Basket with Organizer, Ice Maker, Available Left Hand Hinge

