

# WALL OVEN FEATURES AND SPECIFICATIONS

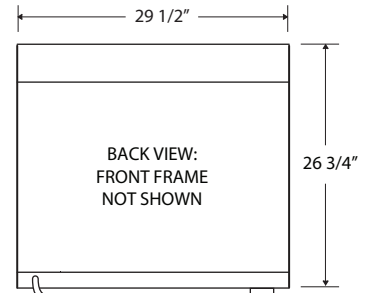
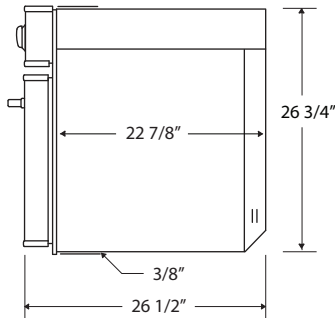
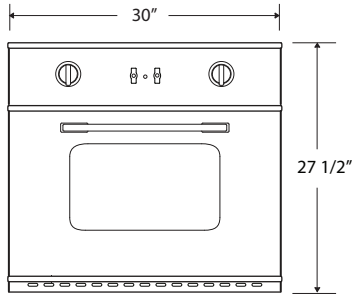

LOCATION OF ELECTRICAL CONNECTION. ATTACHED TO 20" FLEXIBLE CONDUIT.

## FEATURES

- \*4 cu.ft. Large Oven Capacity
  - \*2500 watt bake element
  - \*5000 watt broil element
  - \*Selectable convection mode
  - \*Coved corner interior with removable bottom for easy cleaning
  - \*Heavy duty, full extension oven racks
  - \*1 Years Part and Labor Warranty
  - \*Traditional black/white stippled interior
  - \*Heavy-duty, stainless steel construction
- \*Can be installed in wall or island
  - \*800 watt rear element
  - \*Simple controls
  - \*Can be stacked to double capacity

## Oven Capacity

The cavity design of the oven provides the most precise temperature control, which delivers even heat distribution resulting in versatile performance. It has the largest oven capacity available on a 30" range and will accommodate a full-size commercial 18" x 26" baking sheet.

## Electrical Requirements

240 Volt, 60 Hertz, 35AMPS, Single Phase  
 \*(Unit must be on a non-GFI, dedicated outlet)



## CABINET CLEARANCES

\*RECOMMENDED CABINET WIDTH IS 33"

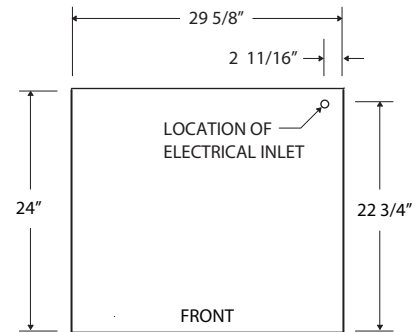
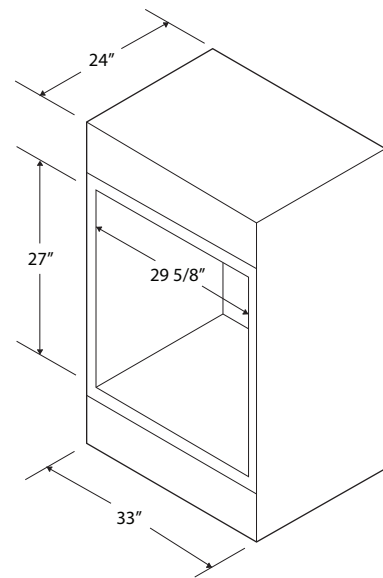

TOP VIEW CABINET

